

Centrevol
Technical Rider
Contact: Peter Guinta (603) 370-0858

Centrevol tours as a 4-piece band, providing their own instruments, instrument cables, drums, guitar amplifiers, and applicable stands.

We will require the following from the event host:

STAGE: Minimum size 16' wide x 12' deep x 2' high. We can work with more or less space, let us know in advance.

MAIN SPEAKERS: 2 3-way cabinets with sub, mid, and horn. Good brands are EAW, Meyer, Clair Brothers or JBL. (No ceiling speakers, Peavy, Bose or PA –on-a-stick systems please!)

POWER AMPS: Make sure you have enough watts to drive the Main Speakers and Monitor Speakers, as well. Recommended amplifiers include: QSC, Crest and Crown.

MIXING CONSOLE: Min 8 channels w/ individual controls for Gain, High, Mid, & Low EQ. Monitor Send, Effects & Volume.

MONITOR SPEAKERS: 4 2-way cabinets with woofer and horn. Brands are EAW, Meyer, Clair Brothers, and JBL.

MICS & DIRECT BOX:

3 Vocal mics
1 Mic or Direct XLR for Bass
1 Mic for Guitar Amp #1
1 Mic for Guitar Amp #2
1 Direct XLR for Keyboard
Drum mics when available
Plus all cables, boom stands, & mic clips.

LIGHTS: Minimum 3 adjustable colored lights and the ability to make the hose completely dark

A/C POWER: 3 -10' extension cables with dedicated power strips.

RUG: one 4' X 6' carpeted rug for use underneath the drum set.

centrevol stage plot

contact: peter (603) 370-0858

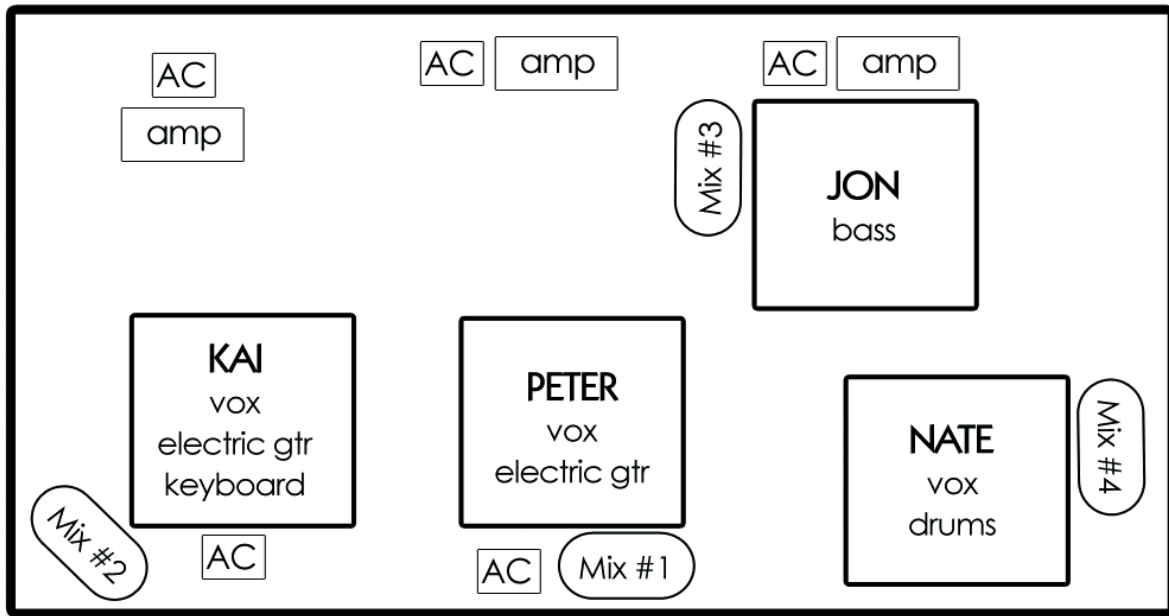

Audience

(Note: Band member positions subject to change based upon stage dimensions available.)

The following tech list is the ideal setup for Centrevol.

Experience shows that the best quality sound & performance comes from hiring a professional sound company/engineer. Nonetheless, our setup is flexible upon the specifics of each event. Please don't hesitate to call and discuss alternatives.

PREFERRED INPUT LIST:

1. Kick
 2. Snare
 3. Hi-Hat
 4. Rack Tom
 5. Floor Tom
 6. Overhead Left
 7. Overhead Right
 8. Bass Amp (artist has built-in D.I.)
 9. Keyboard - Stage Right (artist has XLR out)
 10. Electric Guitar Amp - Stage Right
 11. Electric Guitar Amp - Center
 12. Background Vocal Stage Right
 13. Lead Vocal Center -
(artist has mic, Beta SM87; needs phantom power)
 14. Background Vocal Stage Left
- *** All mic boom stands, mics & cables

MONITOR MIXES

Instruments listed in order of volume level (highest to lowest.)

MIX #	
1	Peter vocal Other vocals Keyboard Guitars Bass Kick/Snare

MIX #	
2	Kai vocal Other vocals Keyboard Kai Guitar Bass Kick/Snare

MIX #	
3	Other vocals Keyboard Guitars Kick/Snare

MIX #	
4	Nate vocal Other vocals Kick Bass Keyboard Guitars